



Hoyer VMS Energy-Saving System

# Find hidden savings in your onboard motors

Together  
we outsmart  
the ordinary

**HOYER  
VMS**

GROUP

**For over 50 years, we have been a global leader at sea.**

When it comes to maritime motor applications, we can meet almost any challenge on any type of vessel.

Through a comprehensive suite of add-on products and digital ESS solutions, we go beyond motors to accelerate shipowners' and operators' efforts to improve energy-efficiency and meet sustainability targets on both new build and retrofits.

Our unique testing facilities in Denmark and China provide documented proof of performance and certification that verifies compliance with international standards, ensuring safety, streamlining approvals, and boosting customer confidence.



- Introduction . . . . . 3
- Executive Summary . . . . . 4
- The challenge . . . . . 5
- What is Hoyer VMS ESS . . . . . 6
- Hoyer VMS ESS applications . . . . . 7
- Business Case: European shipowner . . . . . 10
- Project process and timeline. . . . . 11



# Outsmart Rising Costs and Tightening Regulations at Sea

Faced with increasing pressure from environmental regulations, volatile market conditions, and rising operational costs, the marine industry must find new ways to improve vessel efficiency.

With MARPOL Annex VI mandating regulatory restrictions for air pollutants and **the IMO's target of a 70% reduction of emissions by 2050** looming ahead, shipowners have limited time to get emissions under control. **The Energy Efficiency Existing Ship Index (EEXI) and the Carbon Intensity Indicator (CII)** add even more pressure to reduce energy consumption and carbon emissions for entire fleets, including the vessels already in operation.

Fortunately, several **cost-effective technical and operational measures** can help accomplish these goals. Energy-intensive systems, such as cooling and HVAC systems, represent **a major opportunity for**

**optimisation.** Retrofitting vessels with Energy-Saving System (ESS) not only reduces fuel consumption, but also enhances operational efficiency, and provides **a clear return on investment (ROI).**

This whitepaper explores the opportunities for energy optimisation aboard marine vessels and introduces **Hoyer VMS ESS, a customised Energy-Saving System retrofit solution** that can help shipowners meet regulatory, environmental, and economic goals.



At a glance

# Hoyer VMS ESS

## What is Hoyer VMS ESS?

Hoyer VMS ESS combines Variable Speed Drives (VSDs), sensors, and automation to significantly reduce energy consumption and optimise the operation of multiple pumps and fans application aboard ships.

## Which ship applications can be optimised?

- Sea water cooling pumps
- Engine room fans
- Low-temperature freshwater cooling pumps

## What are the main Benefits?

- Average energy savings of **40-65%** or higher
- Decrease in **environmental impact**, including CO<sub>2</sub>, SO<sub>x</sub>, and NO<sub>x</sub> reductions
- **Extended lifespan** of critical components through reduced wear and tear
- Full ROI in less than **2 years**

## Tailored for the marine industry

- **Customised** solutions for specific ship types and designs
- **Robust** and reliable products designed for demanding marine environments
- **Retrofit** installation while the ship is in operation.
- **Comprehensive** support services, including remote support options

The challenge

# Oversized and Overrunning: The Hidden Cost of Inefficient Vessel Systems

Marine vessels operate in diverse and often unpredictable conditions, requiring their cooling pump systems, HVAC, and engine room fans to function efficiently across a wide range of environments.

The ability to **adapt to these conditions** is critical for maintaining optimal performance, reducing energy consumption, and ensuring crew and equipment safety.

## Understanding over-sizing of ship systems

Due to the tendency of both shipbuilders, owners, and operators to favor conservative safety margins and redundancies, these systems are often designed with **maximum capacity** in mind to handle the most demanding scenarios – such as traveling at full speed in 32° C (90° F) water. However, **in typical operations, this leads to significant inefficiencies**, increased wear, and wasted energy, especially when adaptive control is not available.

Many ships still use throttles and by-pass loops to control their pump systems, which is an **outdated practice**. Essentially, this is equivalent to controlling the flow of water by pinching the hose or redirecting excess water elsewhere while running the tap at full speed.

This **“one-size-fits-all” approach results in energy inefficiencies**, excessive fuel consumption, and premature wear on components. Oversized pumps also increase the risk of cavitations, a condition that can severely damage the pump.

## From constant speed to full control

Being able to adjust the speed of the pump or fan to **match the actual requirement** is both safer and more efficient.

For instance, a container ship navigating through the Panama Canal must carefully regulate its energy use. Even during the slow, controlled transit through calm waters, the tropical climate and high humidity place significant demands on cooling systems to maintain comfortable working conditions for the crew.

By contrast, when the same ship reaches the chill waters of Rotterdam, it can run the cooling pumps and HVAC systems at reduced capacity while offloading the cargo. **Without adaptive control, the pumps and fans would continue to run at maximum levels, leading to wasted energy** and increased wear on the equipment.

## The benefits of Energy Saving Systems

Retrofitting vessels with Hoyer VMS Energy-Saving System (ESS), which includes variable speed drives and automated control solutions, enables the crew to **dynamically adjust the performance of the pump and HVAC systems** based on the ship's speed, water temperature, and weather conditions.

**This adaptability ensures energy is used only where and when it is needed.**

# Save fuel with reduced energy consumption

## Introducing Hoyer VMS ESS

Hoyer VMS ESS is a highly customisable application for marine vessels that combines the use of Variable Speed Drives (VSDs), sensors, and automation to significantly reduce energy consumption and optimise the operation of cooling pumps and engine room fans.

The ESS analyses real-time data and dynamically adjusts the speed of fans and pumps via frequency converters to match operational demands, such as sailing speed, water temperature, and ventilation requirements.

### For example:

- If engine room temperatures rise, sensors trigger the system to increase fan speeds to improve ventilation.
- If freshwater cooling demand drops, sensors prompt the system to reduce pump speeds, saving energy without compromising performance.

## Main features

- **Variable Speed Drives (VSD)** connected to each fan or pump to enable dynamic and precise motor control.
- **Sensors** in pumps to monitor temperatures and pressures.
- **Intelligent control** algorithms that adjust the fan speed and pump pressure based on data from the sensors.
- **MODBUS protocols** (TCP/IP or RTU) to enable seamless integration with Alarm Monitoring Systems (AMS) and Condition Monitoring Systems (CMS) for performance monitoring and predictive maintenance.
- **Intuitive** Human-Machine Interface (HMI) located in the Master Control Panel or Engine Control Room (ECR) to enable ship crews to monitor critical data such as fan speeds, pump pressures, and energy savings.
- **Remote Support** and system upgrades via a secure cloud-based interface as part of Hoyer VMS After Service.
- **Condition based** maintenance (option) to ensure proactive maintenance of fans and pumps.
- **Modular** design approach that enables Hoyer VMS ESS to be customized to match the needs of each specific vessel.

## The benefits of Hoyer VMS ESS

- **Energy savings:** Precise sensor data prevents overuse of pumps and fans, significantly cutting fuel and energy consumption by **40-65%**, depending on the system.
- **Decrease environmental impact:** CO<sub>2</sub>, SO<sub>x</sub>, and NO<sub>x</sub> reductions from less fuel use.
- **Optimised performance:** Intelligent adjustments ensure systems operate efficiently under varying conditions.
- **Reduced workload:** Automated control minimises manual adjustments and oversight.
- **Extended equipment lifespan** by reducing wear and tear on the system.
- **Improved monitoring:** Real-time visibility of temperatures, pressures, and flow rates via the HMI.

# Hoyer VMS ESS Applications

## Engine Room Fans

Engine room fans are essential for maintaining proper ventilation and cooling in the engine compartment, where ambient temperatures can rise significantly under high-load conditions.

In addition to the engine room, the purifier room and the genset room also require adequate ventilation. Traditionally, these fans operate at fixed speeds, leading to unnecessary energy consumption when cooling demands fluctuate.

### Hoyer VMS ESS Optimisation

The Hoyer VMS ESS system integrates sensors in the engine room to monitor ambient temperature and, in some cases, differential pressure. This real-time data is fed into the system's control algorithm, which adjusts fan speeds via VFDs. For example, during low-load conditions or cooler weather, the system reduces fan speeds, maintaining adequate ventilation while consuming less energy.

In the purifier room, where oil separation generates heat, fans operate at higher speeds during peak activity and reduce speed during idle periods. In the genset room, fan speeds adapt based on the load of the auxiliary generators.

### Benefits

- **Energy Savings:** Reduces fan power consumption by up to 50%.
- **Improved Efficiency:** Ensures fans operate only at the required speed, minimising overuse.
- **Reduced Maintenance:** Less mechanical stress extends the operational life of the fans.

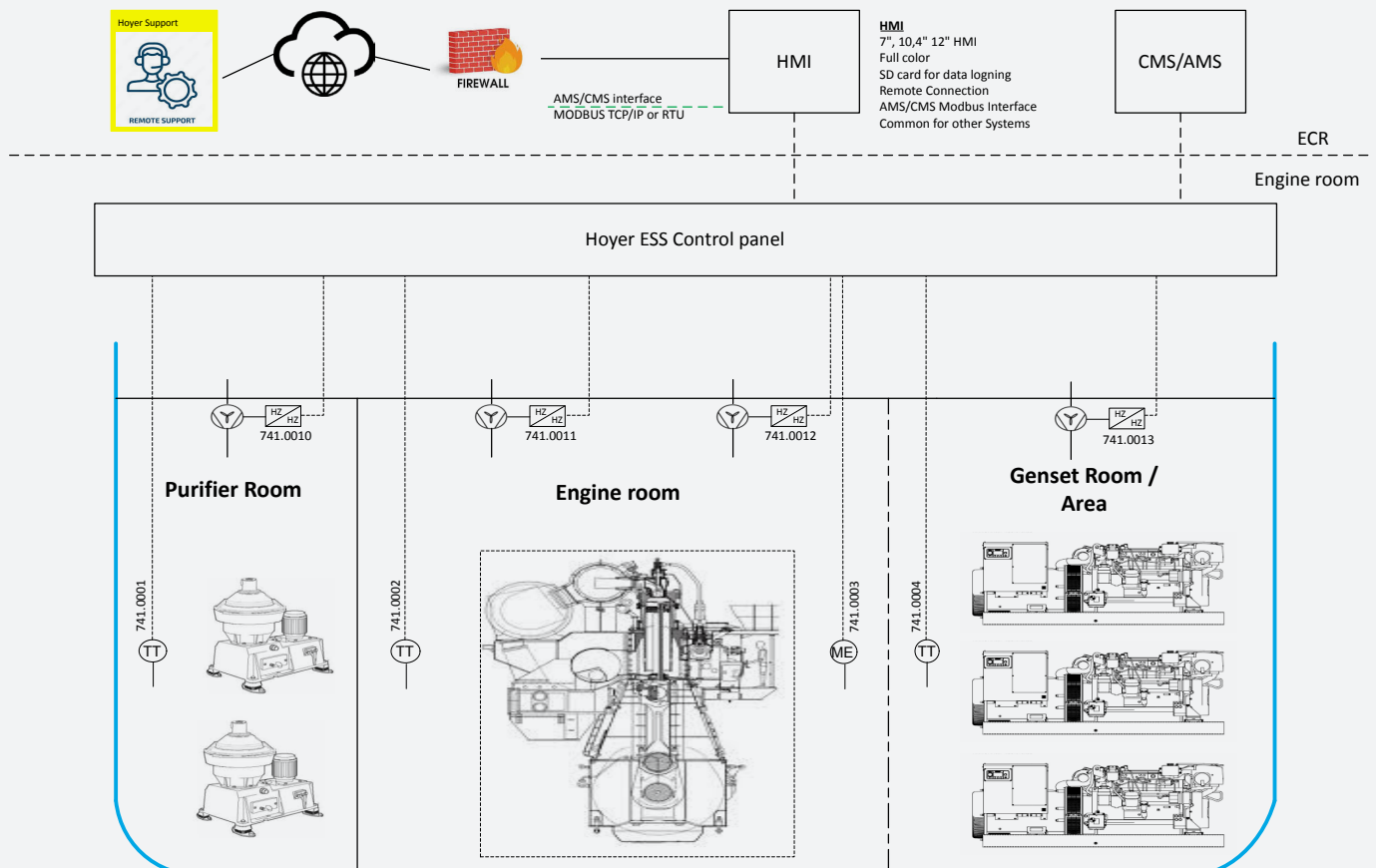

## Hoyer VMS ESS Applications

# Seawater Cooling Pumps

Seawater cooling pumps are critical for heat exchange processes, transferring heat from the LT freshwater cooling circuit to the sea. These pumps must maintain sufficient flow to prevent overheating, but fixed-speed operation often leads to overheating, but fixed-speed operation often leads to overcooling and energy inefficiencies.

### Hoyer VMS ESS Optimisation

Hoyer VMS ESS incorporates sensors on the freshwater side of the cooling system to monitor temperature and pressure. Based on this data, the system adjusts pump speeds to match cooling demand. For instance, in cooler seawater or under low engine loads, pump speeds are reduced, cutting energy use without compromising performance.

### Benefits

- **Energy Savings:** Reduces pump energy consumption by 50–65%.
- **System Stability:** Ensures consistent cooling performance under varying conditions.
- **Operational Flexibility:** Adapts seamlessly to different seawater temperatures and operational scenarios.

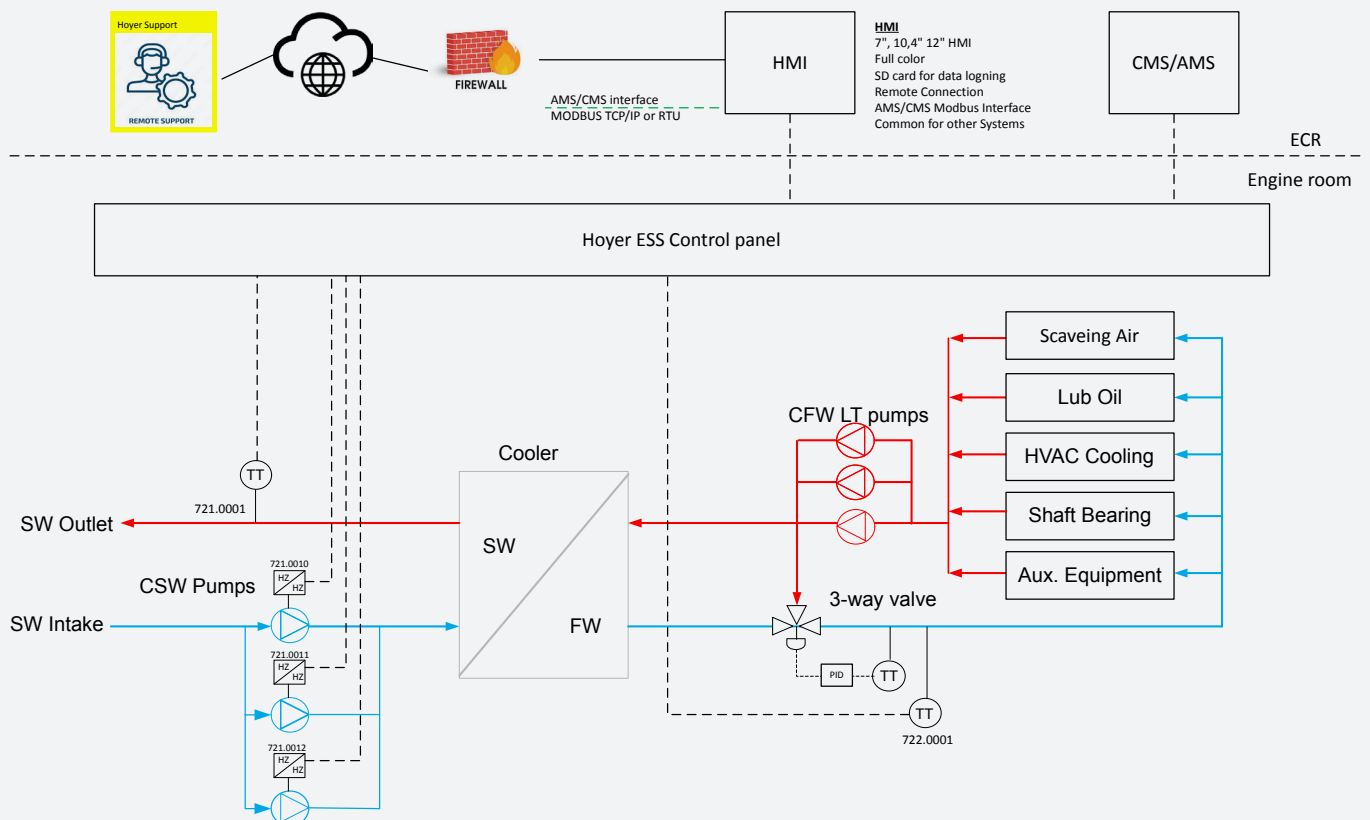

## Hoyer VMS ESS Applications

# LT Freshwater Cooling Pumps

Low-temperature (LT) freshwater cooling pumps supply cooling water to critical machinery, including main engines, auxiliary engines, and HVAC systems. These pumps often operate with surplus capacity to account for peak demands, leading to inefficiencies during normal operation.

### Hoyer VMS ESS Optimisation

Sensors in the freshwater circuit monitor temperature and pressure, enabling the Hoyer VMS ESS system to adjust pump speeds dynamically. For example, during low engine loads or reduced HVAC demands, pump speeds are lowered to optimise energy use while maintaining adequate cooling.

### Benefits

- **Energy Savings:** Cuts pump energy usage by 40–50%.
- **Extended Component Lifespan:** Reduces mechanical wear on pumps and associated equipment.
- **Precise Control:** Ensures cooling water flow aligns with real-time demand.

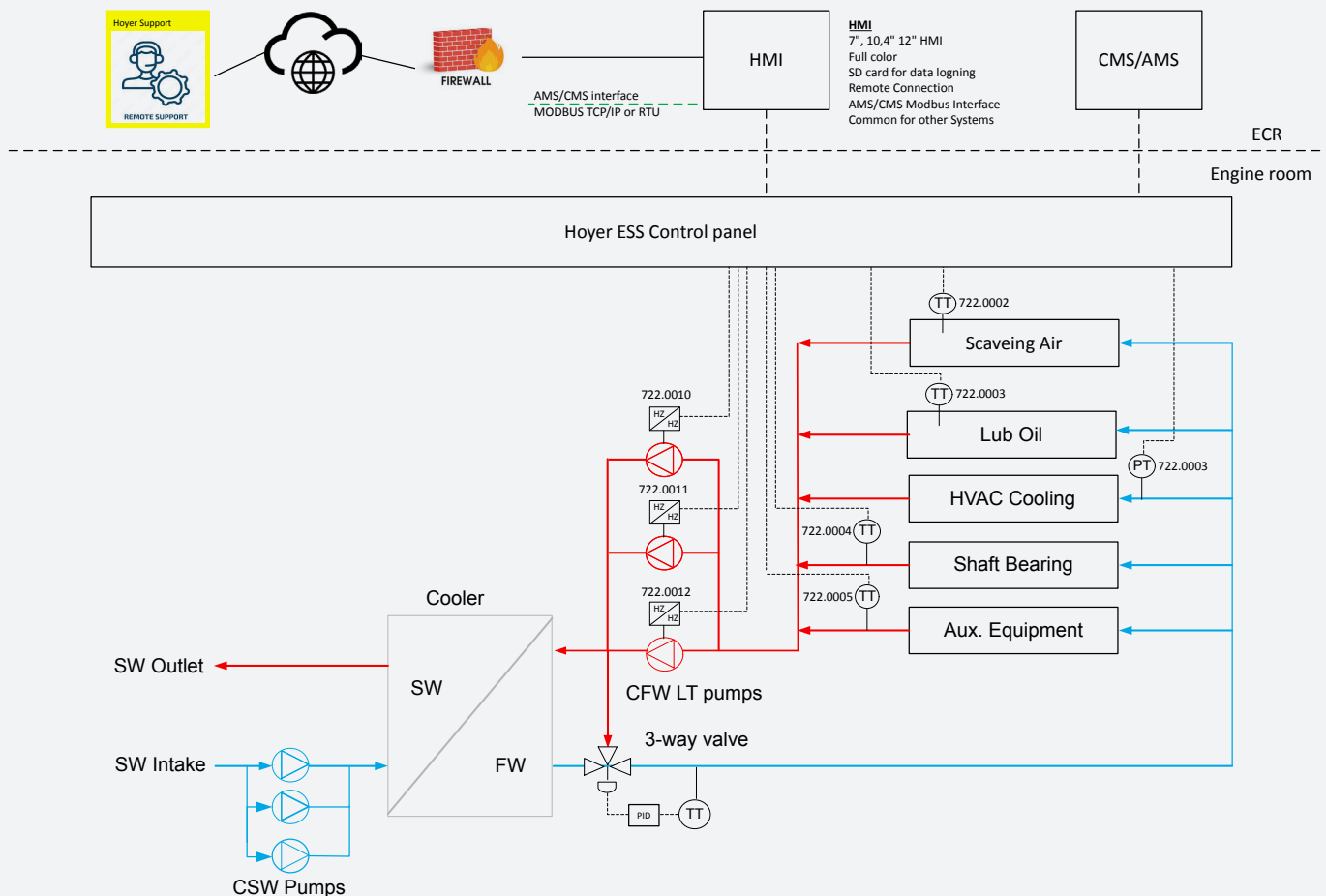

# Improve operations with additional retrofits

- **Motor replacement:** Replacing IE1 motors with more efficient IE4 motors can save around 4-6% energy.
- **General power monitoring:** Hoyer VMS ESS also offers general power monitoring solutions.
- **Performance data collection:** Data collection and analysis to document system performance and business case.
- **Condition-based maintenance** to ensure proactive maintenance of fans and pumps.

## Business Case: European shipowner

# Underway installation. Fast payback times.

A European shipowner retrofitted their vessel with Hoyer VMS ESS to optimise energy use across critical components. This enabled them to achieve significant reductions in both energy use and air pollutant and carbon emissions and a ROI of less than 2 years.

### Implementation

#### Engine Room Fans:

- Number of Fans: 4
- Fan Specifications: 22 kW duty point per fan, 1752 RPM, 75,000 m<sup>3</sup>/h capacity

#### Seawater Cooling Pumps:

- Number of Pumps: 3
- Pump Specifications: 85 kW duty point per pump, 580 m<sup>3</sup>/h capacity, 25 m head

#### LT Freshwater Cooling Pumps:

- Number of Pumps: 3
- Pump Specifications: 51.3 kW duty point per pump, 384 m<sup>3</sup>/h capacity, 30 m head

### Results

#### Energy Savings:

- Engine Room Fans: 337,203 kWh/year (49% reduction)
- Seawater Cooling Pumps: 540,584 kWh/year (54% reduction)
- Freshwater Cooling Pumps: 283,952 kWh/year (40% reduction)
- **Total Savings:** 1,416,832 kWh/year

#### Fuel Savings:

- Total reduction: **290.5 tons/year**

#### Cost Savings:

- Annual energy cost savings: **\$169,283.30**

#### Environmental Impact:

- CO<sub>2</sub> reduction: **628.4 tons/year**
- SO<sub>x</sub> reduction: **12.1 tons/year**
- NO<sub>x</sub> reduction: **20.1 tons/year**

### Return on Investment (ROI)

**Total Investment:** \$280,000 (hardware + installation)  
**Payback Period:** 1.65 years  
**ROI:** 55% annual savings post-payback

# Process and timeline for retrofit installation

Implementing the Hoyer VMS ESS is a structured process designed to maximise potential energy savings with minimal disruption to the ship's operation. In most cases, all the work involved can be carried out while the vessel is at sea.

The project begins with a comprehensive **assessment of the vessel's existing systems**, including a pre-inspection to identify inefficiencies and opportunities for energy optimisation. During this phase, the shipowner is asked to provide technical and operational data, such as technical plans, fan/pump power consumption, and operating hours.

Based on the assessment, a **detailed system design** is agreed upon and prepared for testing, delivery, and installation. Throughout this process, Hoyer VMS's deep domain knowledge of the marine industry and in-house testing centre ensures top quality and documentation, and that the equipment meets all technical and regulatory standards.

Once the finished system is delivered to the vessel, **Hoyer VMS's technical experts** oversee the installation and IO testing as well as crew training. The installation process does not require the ship to be in the harbour or drydock, so it can be carried out while the ship is operating as normal.

While specific durations and system design depend on the vessel size, operational conditions, and equipment configuration, the general process follows these steps:

Phase	Duration	Key milestones
Pre-assessment and budget quotation	2-3 weeks	Operational and technical data collection, onboard pre-inspection
System design	3 weeks	Detailed system design and approval
FAT and delivery	3-6 weeks	Factory Acceptance Test (FAT), packing and shipping, delivery confirmation
Installation	3 weeks	Installation on board, IO test
Commissioning	2 weeks	Systems handover, crew training, project evaluation
<b>Total time from contact to delivery</b>	<b>Approx. 15 weeks</b>	

**Together  
we outsmart  
the ordinary**



**Scan and learn  
more about Hoyer VMS  
Energy-Saving System**

 **Follow us  
on LinkedIn**



#### **Denmark**

Over Hadstenvej 42 • DK-8370 Hadsten  
T +45 86 98 22 55 • F +45 86 98 17 79  
[hoyermotors@hoyermotors.com](mailto:hoyermotors@hoyermotors.com)  
[hoyermotors.com](http://hoyermotors.com)

#### **China**

No.338, Anju Road • Beilun District  
Ningbo 315821 • Zhejiang, P.R.C  
T +86 21 8036 4698 • F +86 574 2628 1573  
[hoyermotors@hoyermotors.cn](mailto:hoyermotors@hoyermotors.cn)  
[hoyermotors.cn](http://hoyermotors.cn)

**HOYER  
VMS**

**GROUP**